

NOTES:-
 1. PRIOR TO COATING, COIN SEAT USING CUT A2500263A AND
 PROCEDURE OUTLINED IN LEE PRODUCTS PROCESS SPECIFICATION
 PS 1013. SEE: www.theleeco.com

Rev	ECN No	Description	Date	Designed by	Checked by
01.0	--	ISSUED	01/05/2017	CCr	IMI

General Limits
unless otherwise stated

Break Sharp Corners	x.xxx [x.xxx] ± 0.02
0.25	
Fillet Radii 0.8	x.xx [x.xxx] ± 0.1
T.I.R. 0.25	
Parallelism 1 in 250	x.x [x.xxx] ± 0.25
Squareness 1 in 250	
Angular Degree ± 0.5	
Surface 1.6 RA	x [x.xxx] ± 0.5

MATERIAL/B.O.M. ZMS-010		FINISH ZTS-001 / QPQ		HEAT TREATMENT NONE	
DRAWN BY			CHECKED BY		
PROJECT			TITLE/NAME		
PROJECTION 		SHEET SIZE A3 PRINT FULL SIZE		DRAWING NUMBER 005735	
REVISION 01.0				SHEET 1 of 3	
DATE DRAWN 01/05/2017					

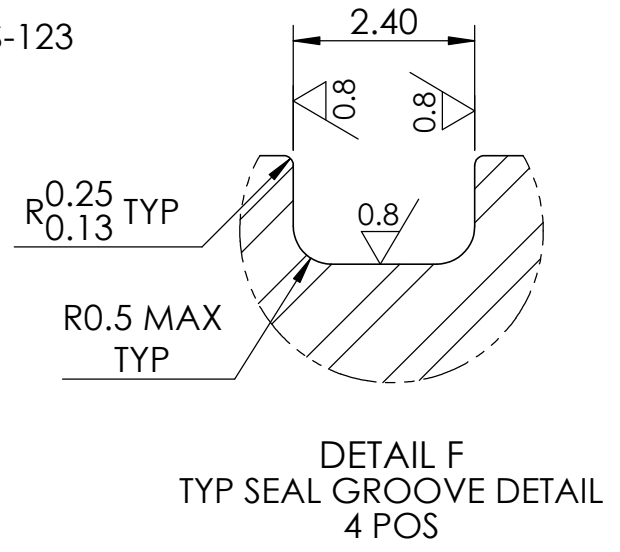
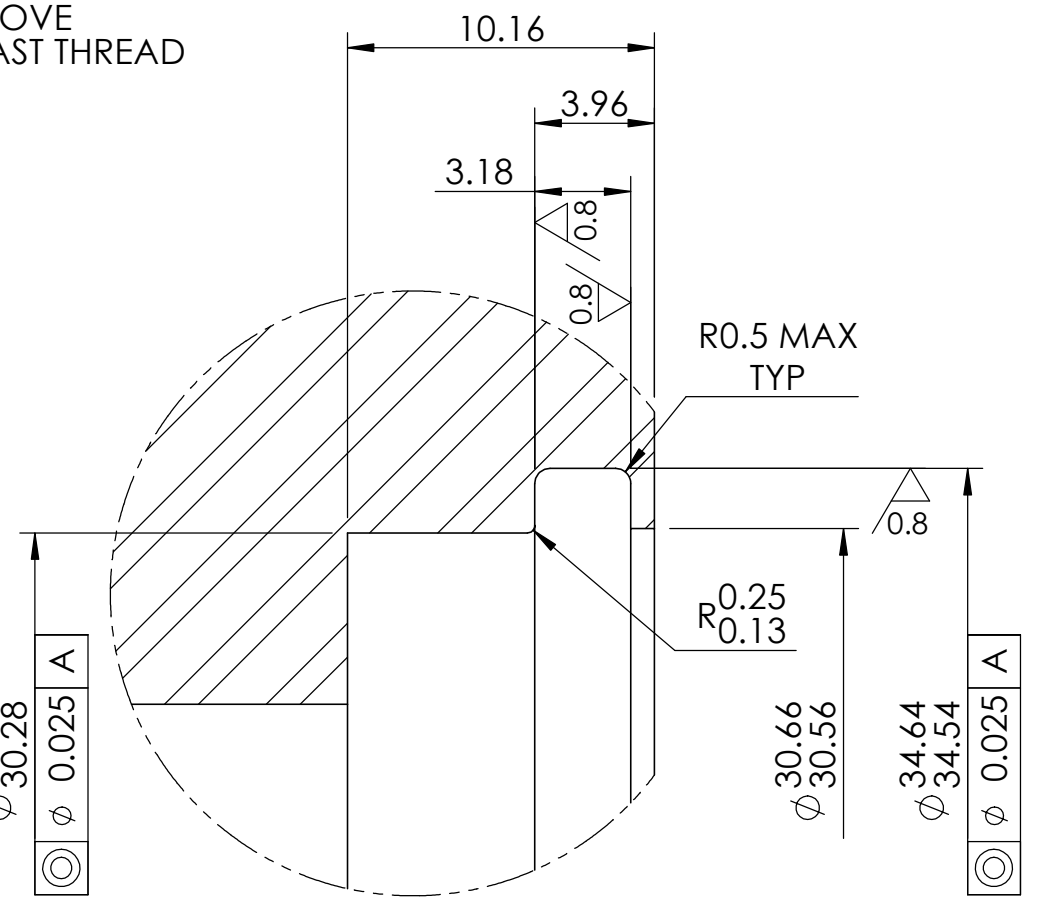
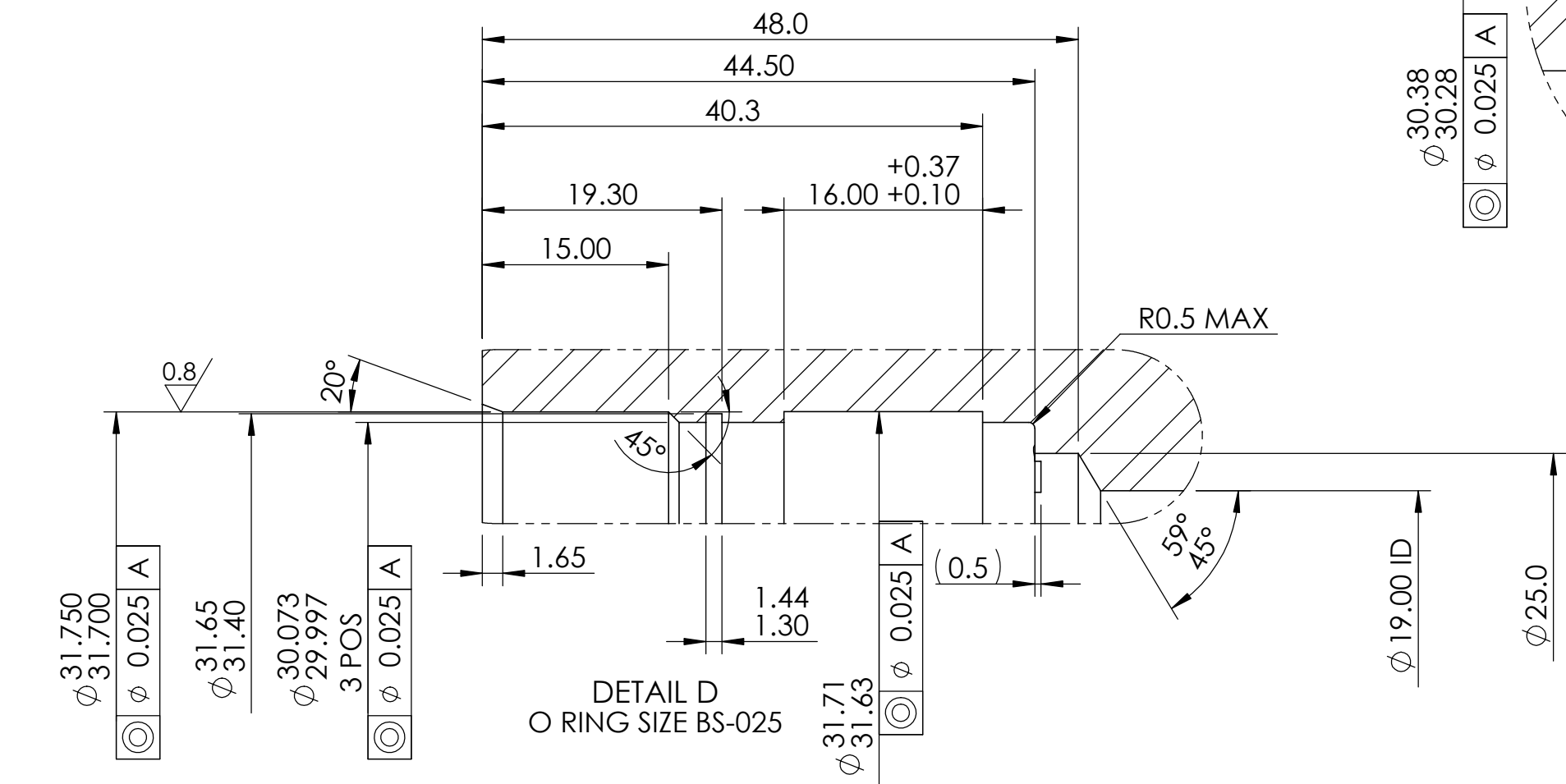
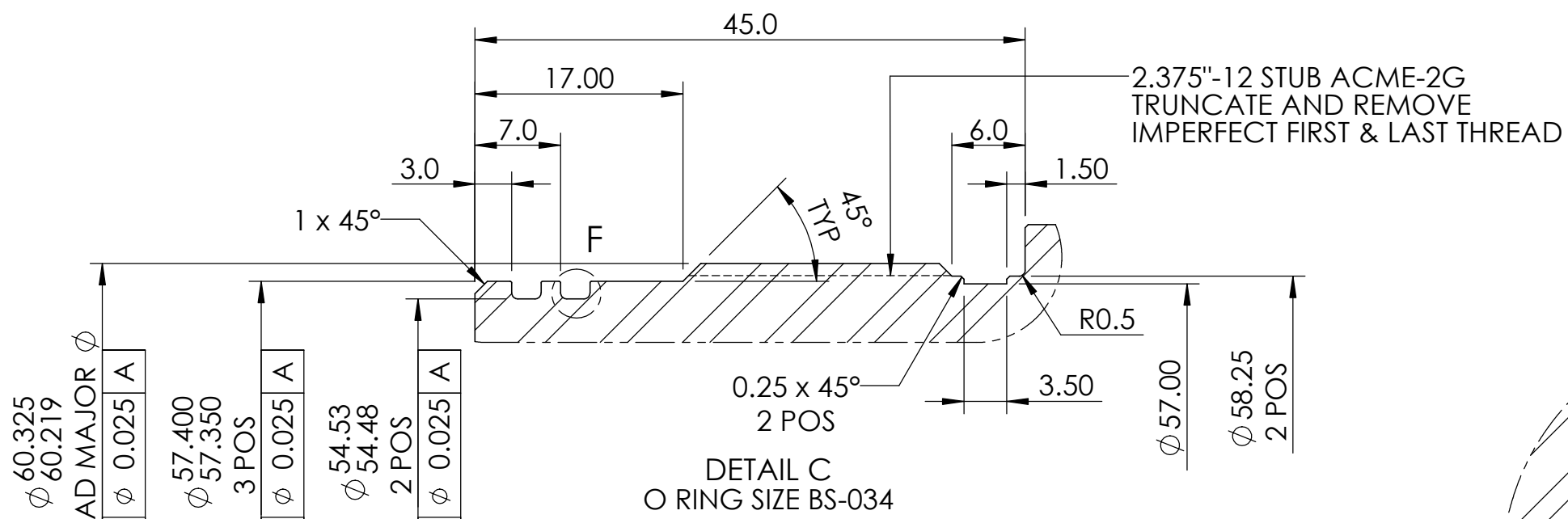

Rev	ECN No	Description	Date	Designed by	Checked by
01.0	--	ISSUED	01/05/2017	CCr	IMI

General Limits
unless otherwise stated

Break Sharp Corners	x.xxx [x.xxx] ±0.02
0.25	
Fillet Radii 0.8	x.xx [x.xxx] ± 0.1
T.I.R. 0.25	
Parallelism 1 in 250	x.x [x.xxx] ± 0.25
Squareness 1 in 250	
Angular Degree ±0.5	
Surface 1.6 RA	x [x.xxx] ± 0.5

MATERIAL/B.O.M. ZMS-010		FINISH ZTS-001 / QPQ		HEAT TREATMENT NONE	
DRAWN BY			CHECKED BY		
PROJECT			TITLE/NAME		
PROJECTION		SHEET SIZE A3 PRINT FULL SIZE		DRAWING NUMBER 005735	
REVISION 01.0				SHEET 2 of 3	
DATE DRAWN 01/05/2017					

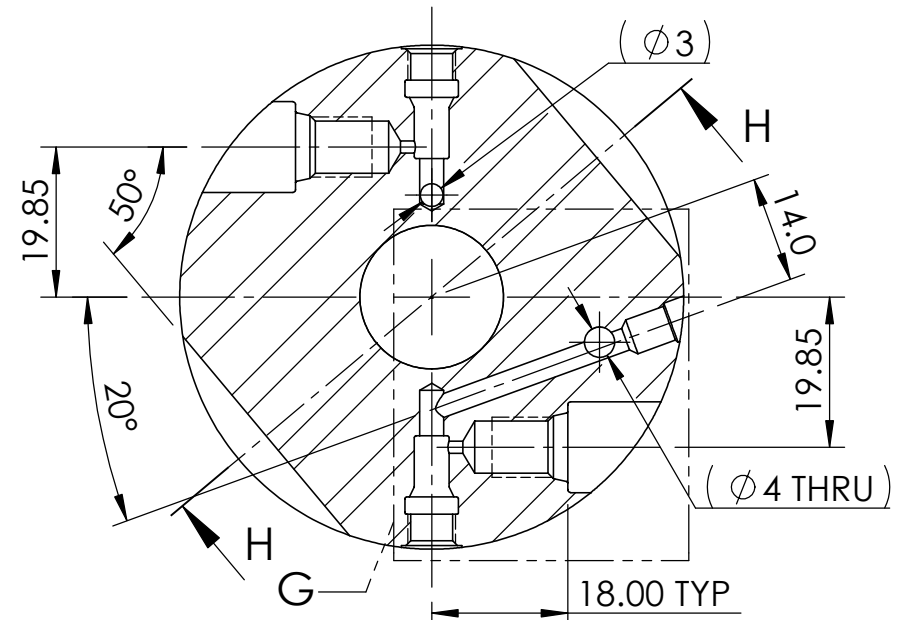

SECTION A-A

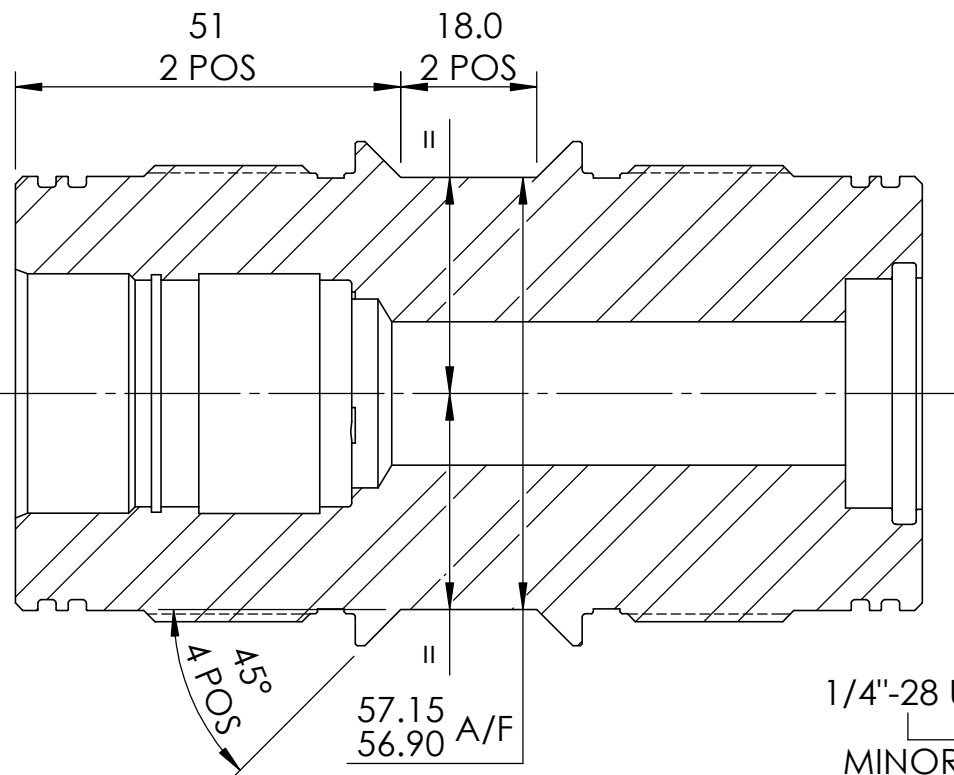

SECTION H-H

LEAVE SHARP, COIN SEAT
SEE NOTE 1

Ø 4.65
Ø 4.60
Ø 0.025 X

R0.25 MAX
3 POS

1/4"-28 UNF-2B MODIFIED
Ø 8.0 x 0.5 DEEP
MINOR Ø: 0.220"/0.225"
6.9 x 90°

Ø 0.13 X

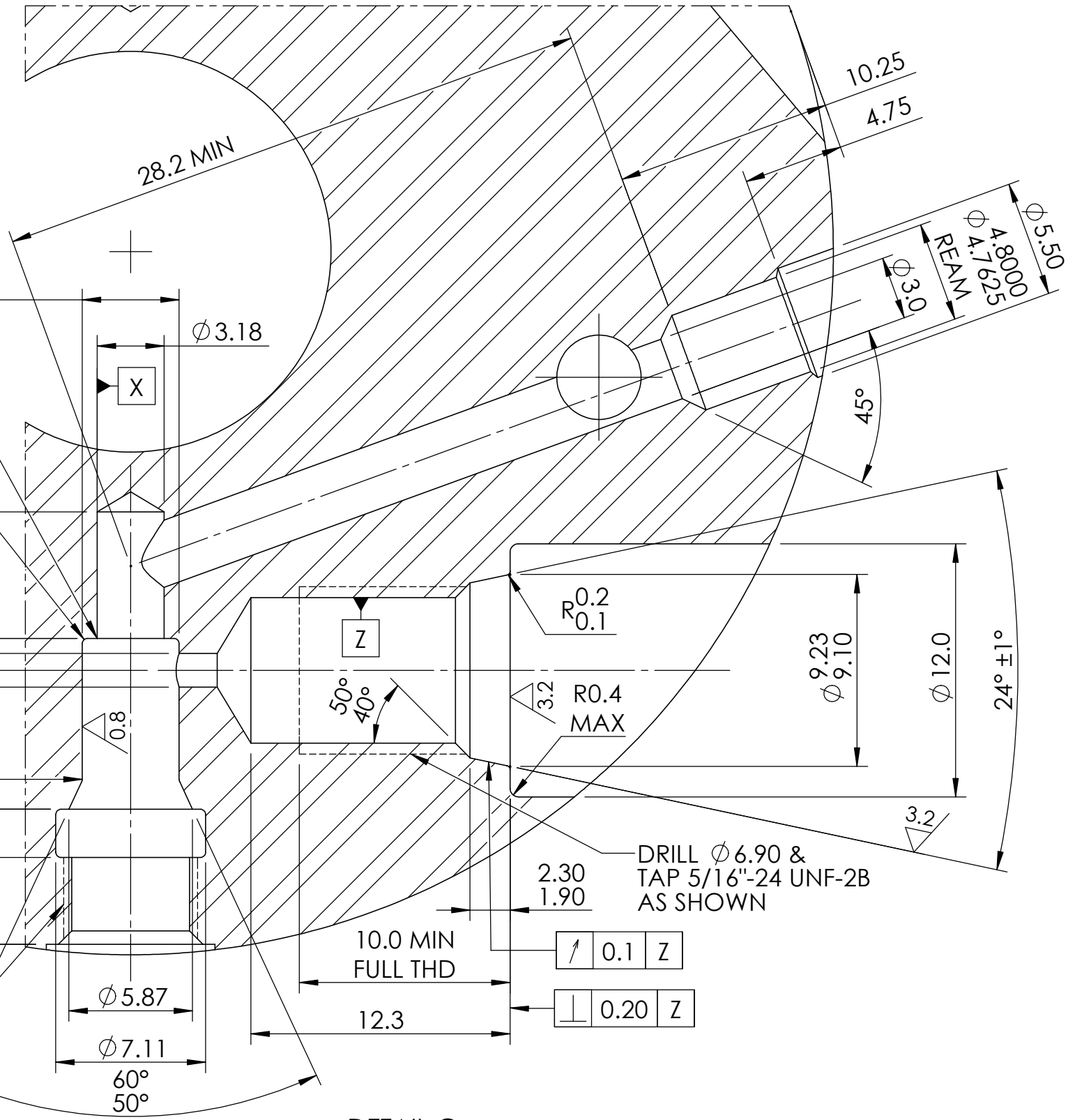

DETAIL G
1/4-28 UNF & 5/16-24 UNF PORT DETAILS TYP TO 2 POS

DRILL Ø 6.90 &
TAP 5/16"-24 UNF-2B
AS SHOWN

General Limits
unless otherwise stated

Break Sharp Corners	x.xxx [x.xxx] ± 0.02
0.25	
Fillet Radii 0.8	x.xx [x.xxx] ± 0.1
T.I.R. 0.25	
Parallelism 1 in 250	x.x [x.xxx] ± 0.25
Squareness 1 in 250	
Angular Degree ± 0.5	x [x.xxx] ± 0.5
Surface 1.6 RA	

MATERIAL/B.O.M.

ZMS-010

FINISH

ZTS-001 / QPQ

HEAT TREATMENT

NONE

DRAWN BY

CHECKED BY

DATE DRAWN

01/05/2017

PROJECT

TITLE/NAME

PROJECTION



SHEET SIZE

A3

PRINT FULL SIZE

PRINT FULL SIZE

DRAWING NUMBER

005735

REVISION

01.0

SHEET

3 of 3

Rev	ECN No	Description	Date	Designed by	Checked by
01.0	--	ISSUED	01/05/2017	CCr	IMI