

A3		ISO 2768 m Średnio dokadne	Długość	0.5-3	3-6	6-30	30-120	120-315	315-1000	1000-2000	2000-4000	4000-8000
			Tolerancja	+/- 0.1	+/- 0.1	+/- 0.2	+/- 0.3	+/- 0.5	+/- 0.8	+/- 1.2	+/- 2	+/- 3

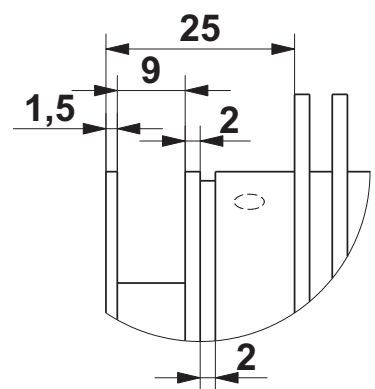

SZCZEGÓŁ O  
SKALA 1 : 1

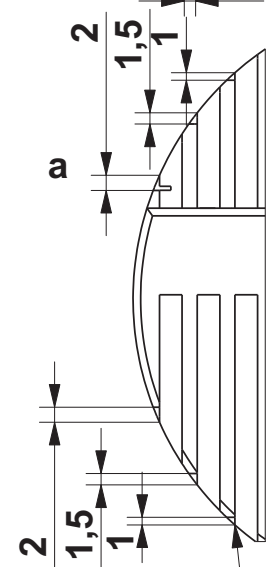
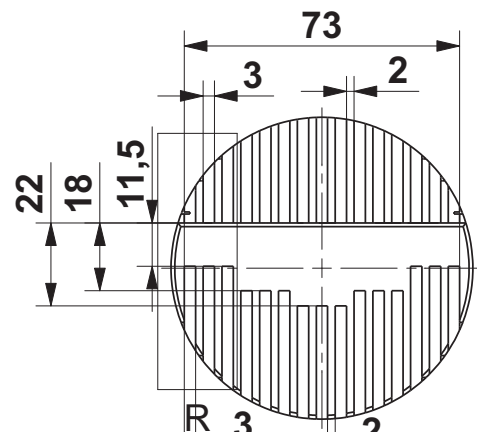

SZCZEGÓŁ R  
SKALA 1 : 1

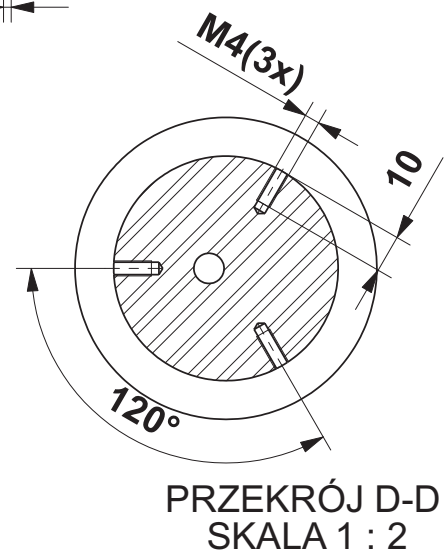

PRZEKRÓJ D-D  
SKALA 1 : 2

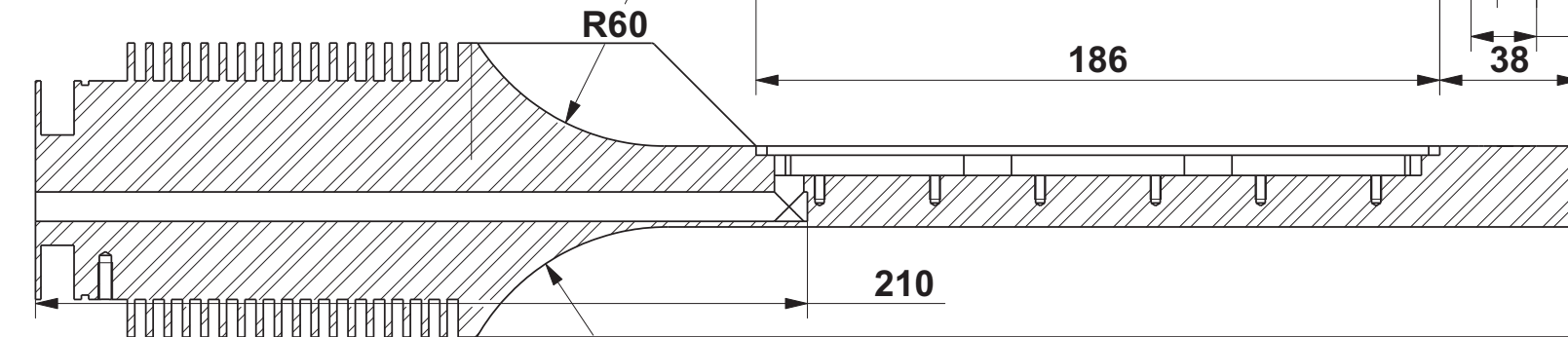
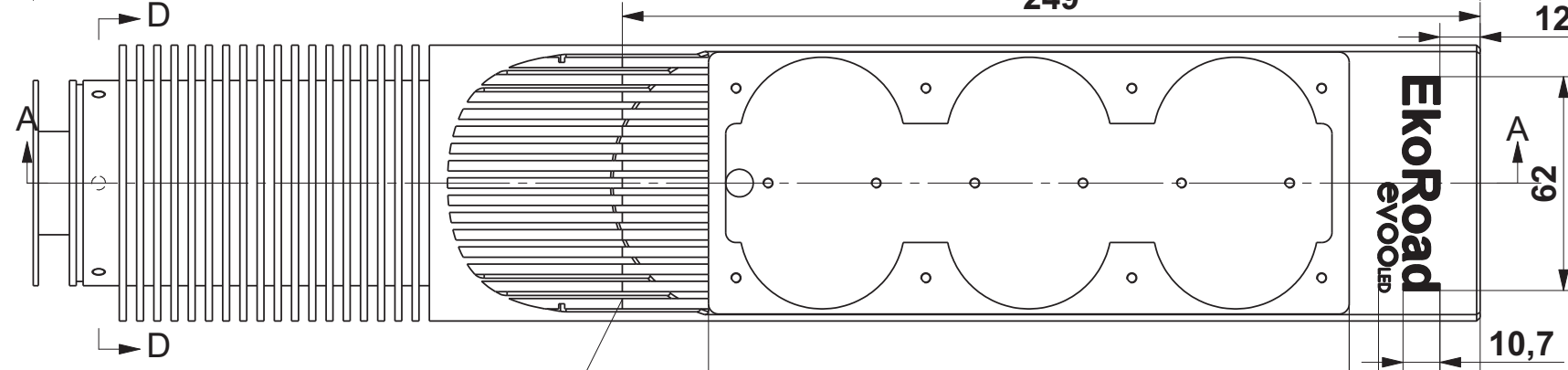
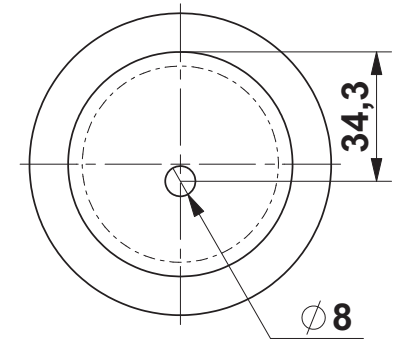
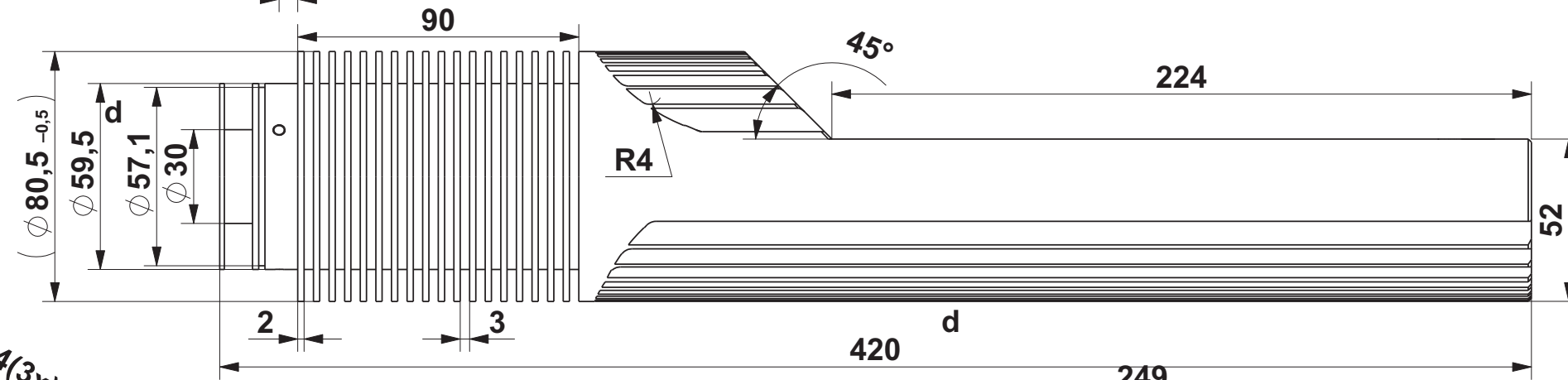
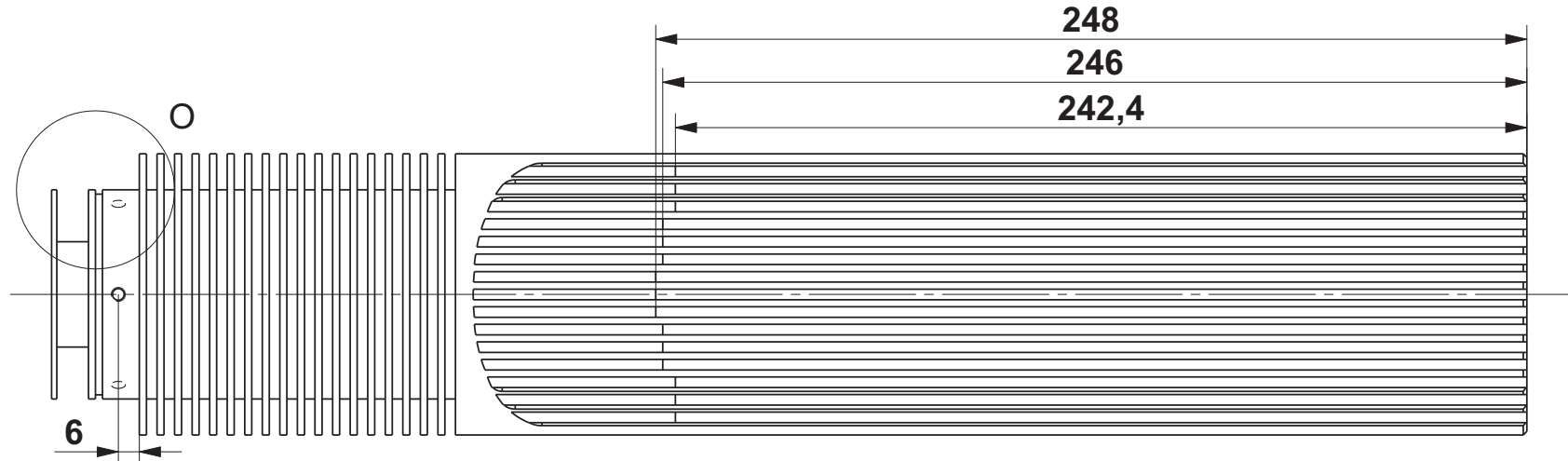

PRZEKRÓJ A-A  
SKALA 1 : 2

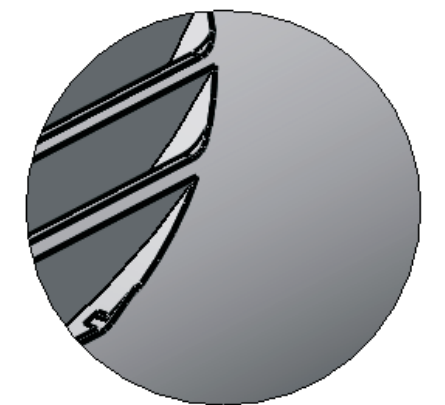

Ścięcia wykonać z obu stron detalu(12x).

A3

ISO 2768 m  
Średnio  
dokładneDługość  
Tolerancja

0.5-3

+/- 0.1

3-6

+/- 0.1

6-30

+/- 0.2

30-120

+/- 0.3

120-315

+/- 0.5

315-1000

+/- 0.8

1000-2000

+/- 1.2

2000-4000

+/- 2

4000-8000

+/- 3

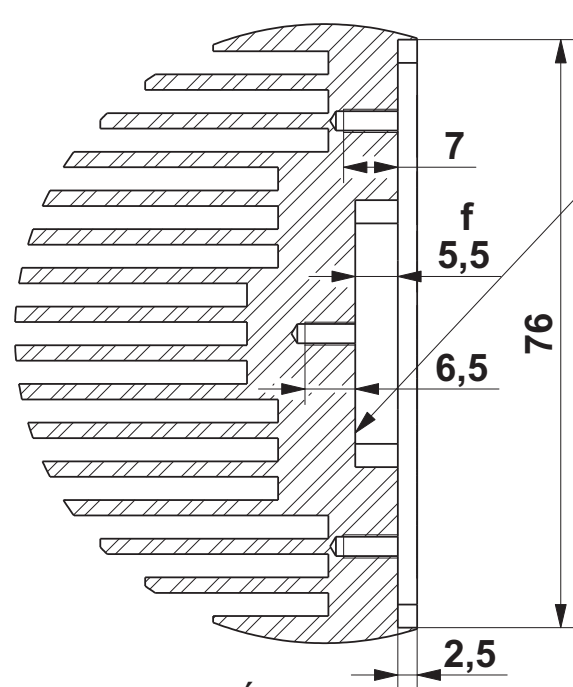
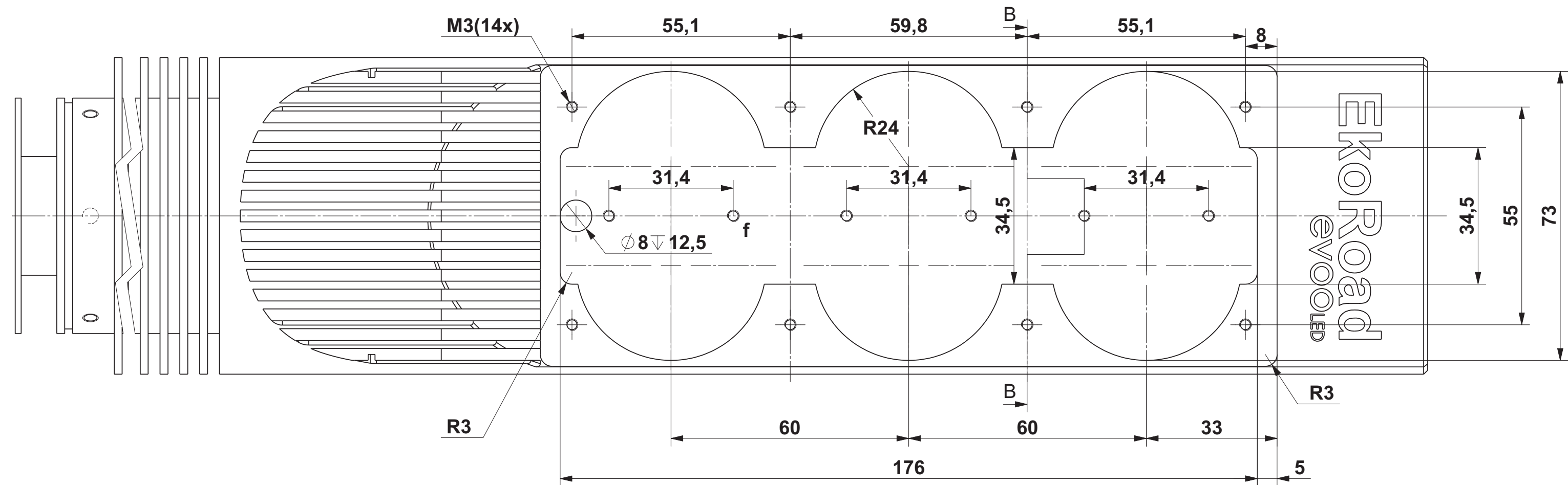

PRZEKRÓJ B-B  
SKALA 1:1

frezowanie wykańczające  
Ra2,5

wykonać fazę 1x45°  
lub promień R1

wykonać fazę 1x45°  
lub promień R1

