

848334843

ENGR	M DOBSON	MD
DRAWN	LV LAWRENCE	LVL ODD
		3-5-99 ISSUE 1

NOTES:
 1. THE GEOMETRY OF THIS PART HAS BEEN CREATED USING UNIGRAPHICS AND IS STORED IN THE ATLANTA UNIGRAPHICS VAULT.

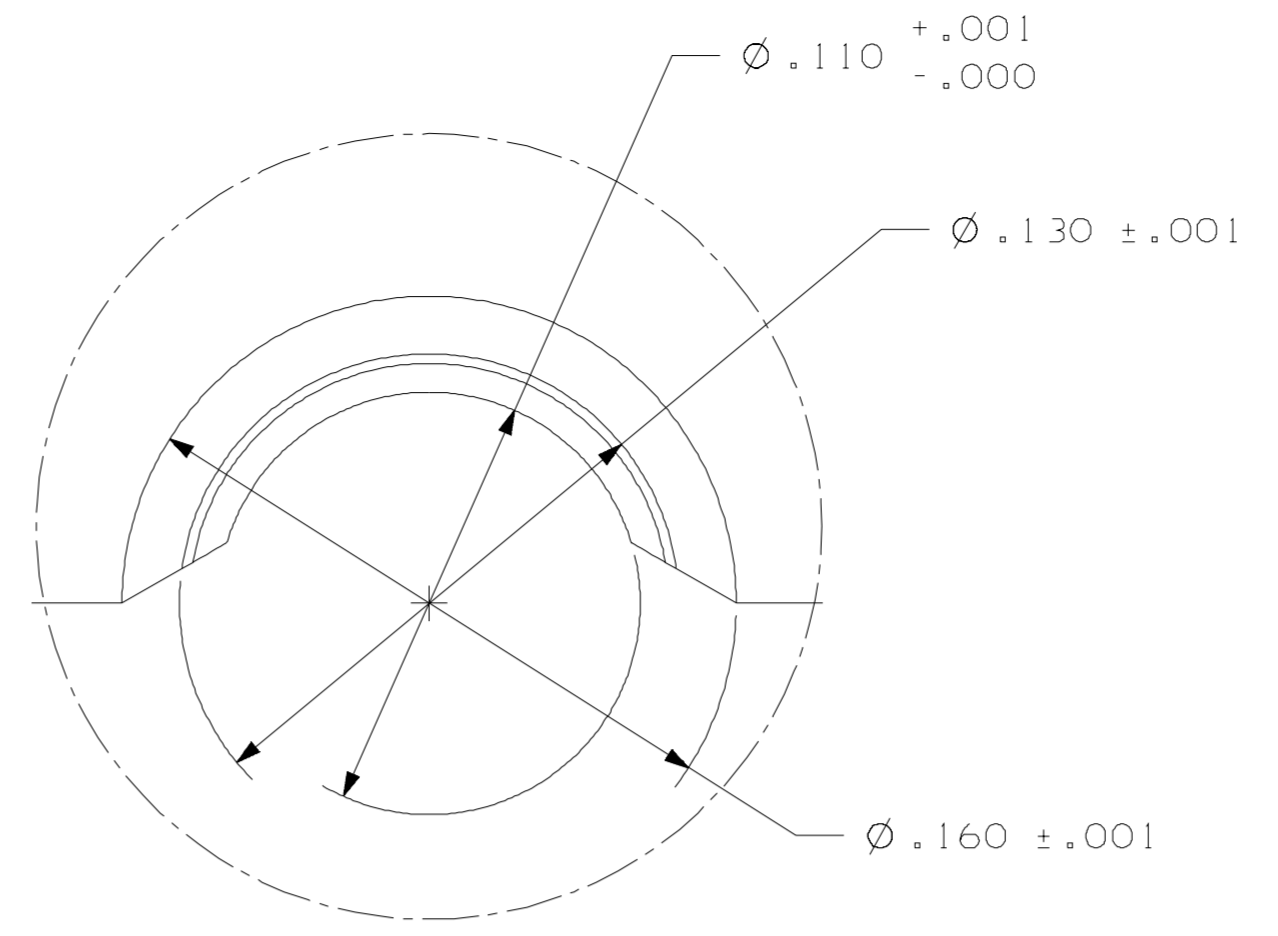
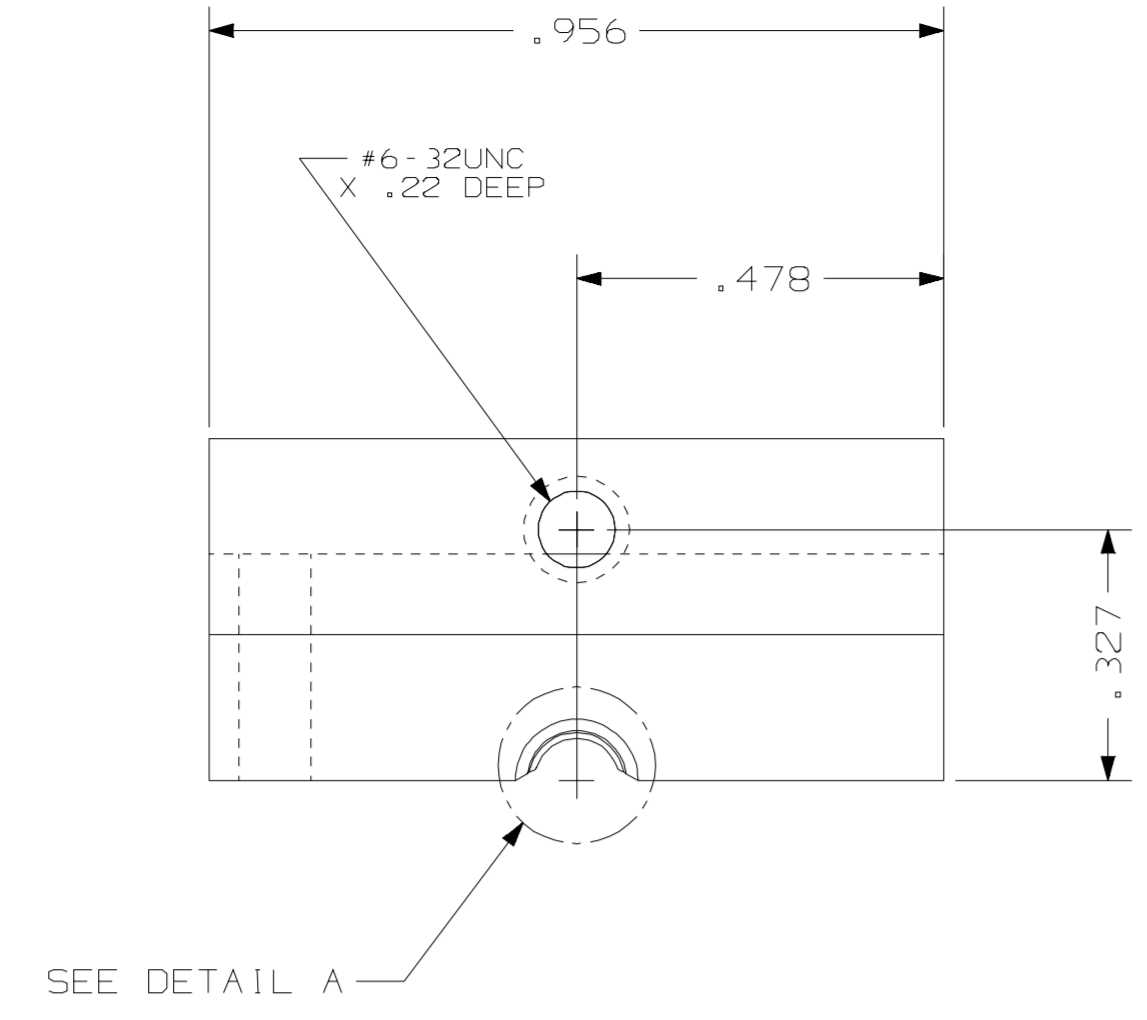

DETAIL A
SCALE 20/1

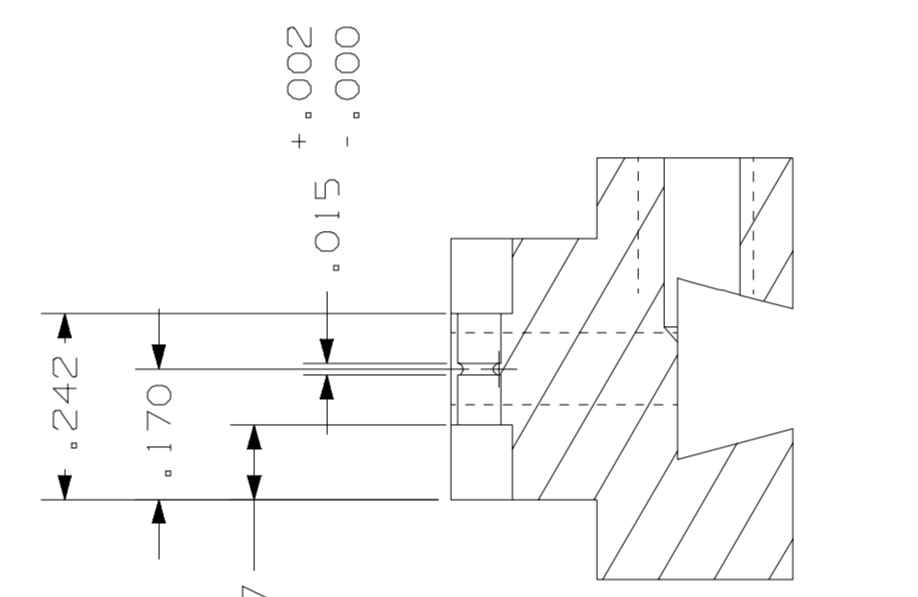
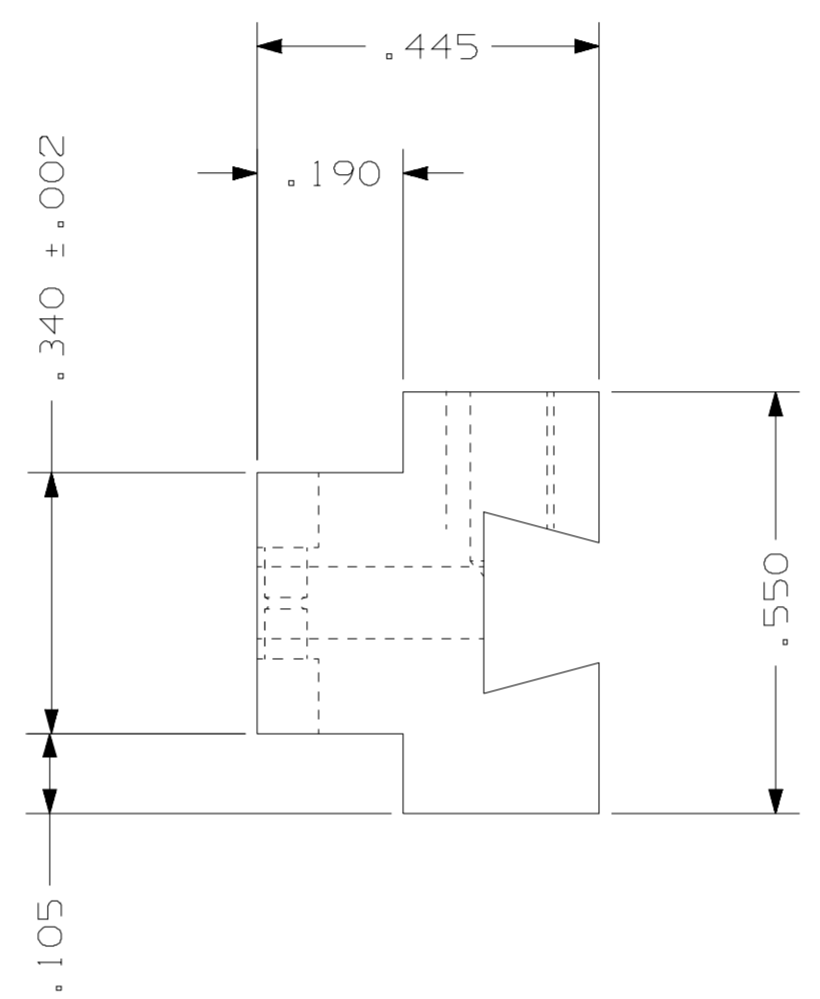
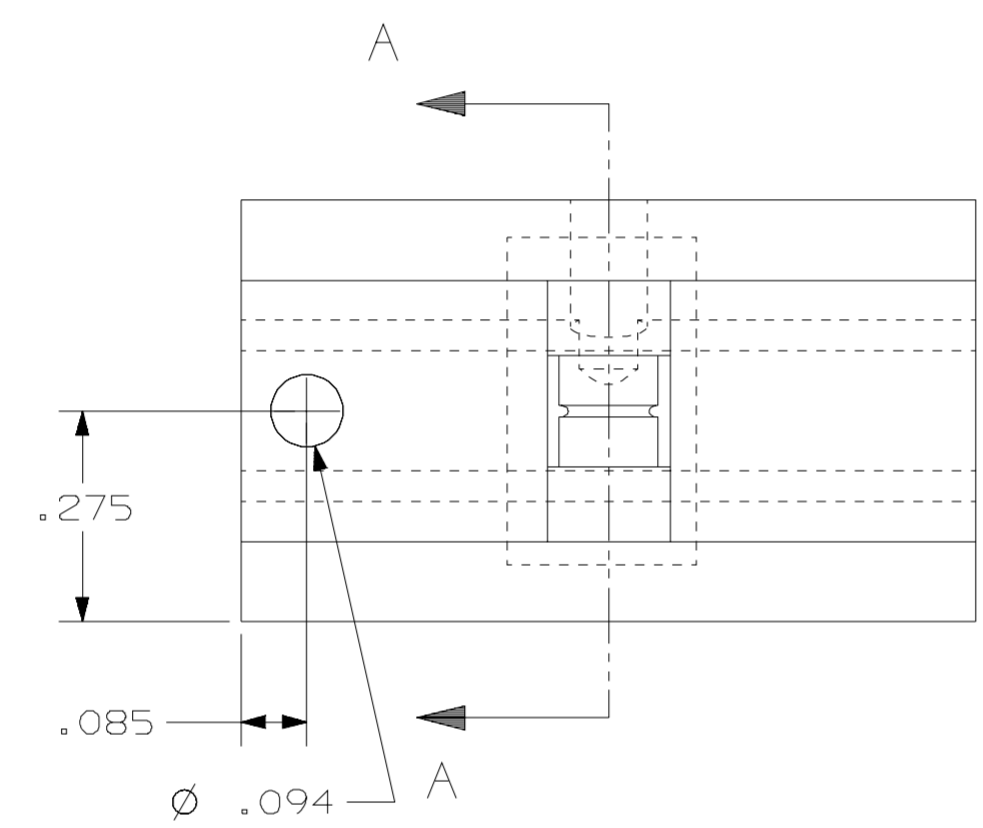
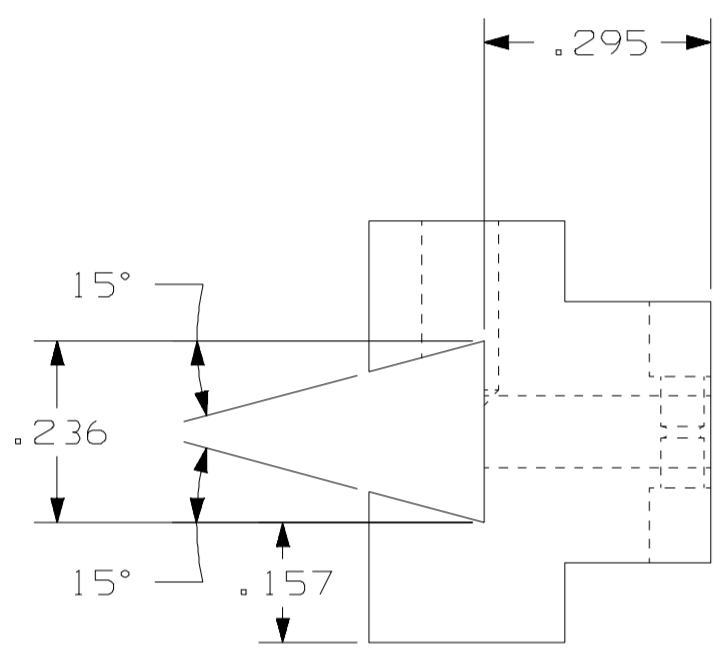
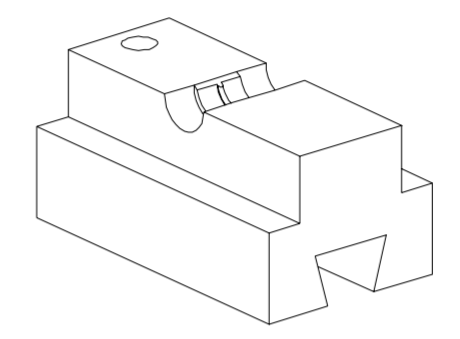

SECTION A-A

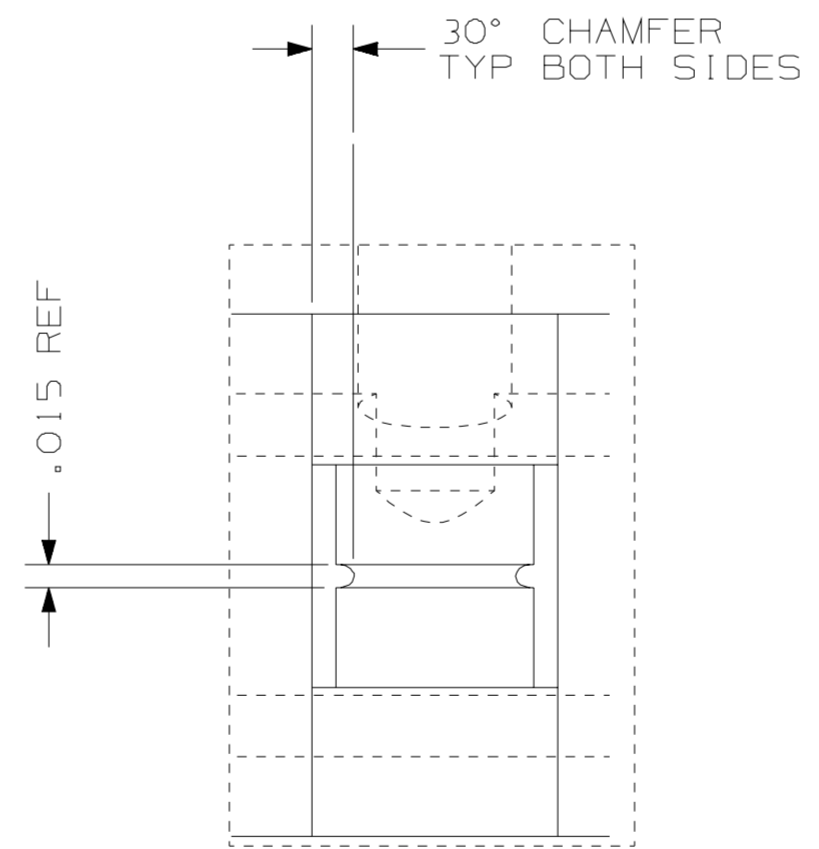
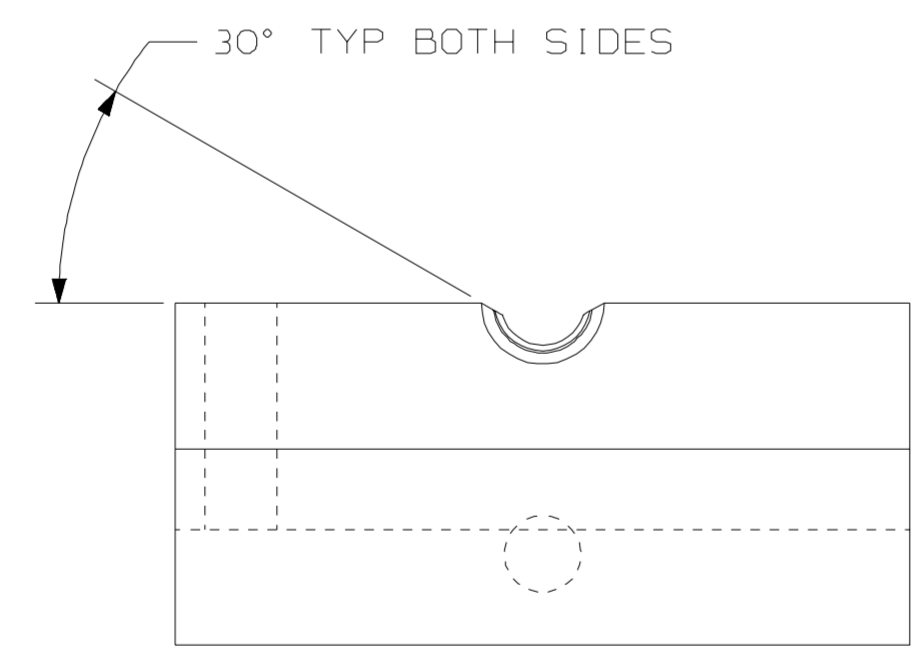

DETAIL B
SCALE 8/1

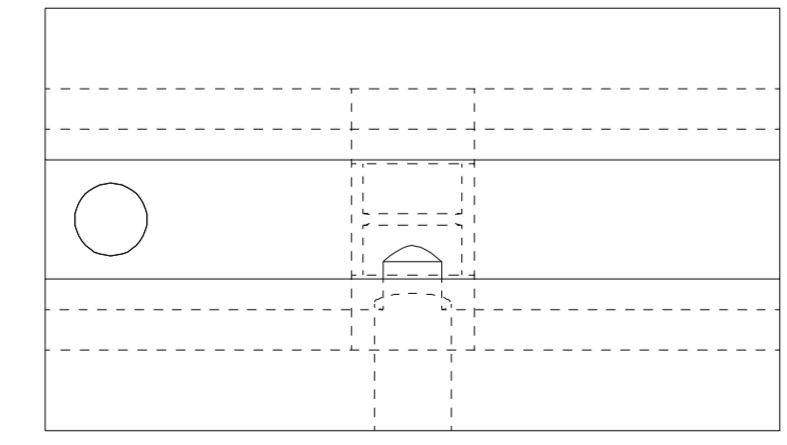

MATERIAL	FINISH
A2 TOOL STEEL	HARDEN TO 56-60 ROCKWELL

UNLESS OTHERWISE SPECIFIED, ALL DIMENSIONS ARE IN INCHES. NONLIMITED DIMENSIONS OTHER THAN SIZE OF RAW MATERIAL SHALL BE HELD AS FOLLOWS WHEN EXPRESSED:
 TO 2 DECIMAL PLACES ± .01 AS ANGLES ± 1°
 TO 3 DECIMAL PLACES ± .005
 THIS ENGLISH DRAWING HAS BEEN PREPARED IN ACCORDANCE WITH ANSI Y14.5M - 1982. DIMENSIONS SHOWN IN BRACKETS () ARE MILLIMETERS AND FOR REFERENCE.

847841442
USED ON DRAWING

Lucent Technologies PROPRIETARY Use pursuant to Company instructions

APPARATUS-EQUIPMENT

CRIMPER, LC, UPPER JAW

SCALE 4/1

DWG SIZE 65

848334843