



# ORANGE PRODUCTS, INC.

1929 VULTEE STREET, ALLENTOWN, PA 18103 USA (610) 791-9711 FAX (610) 791-9531  
www.orangeproducts.com e-mail: info@orangeproducts.com

## PRODUCT SPECIFICATION SHEET

DATE: 2010-03-22 REV. #: A DRAWN BY: TJZ  
 SPECIFICATION #: F113800122012 REV. DATE: 2010-04-05 APPROVED BY: SPS

**ITEM:** 1.138" (28.9mm) POLYPROPYLENE HOLLOW BALL, GRADE 2, FROSTED  
**MATERIAL:** INEOS H13M-00 OR MARLEX HGX-120  
**COLOR:** NATURAL  
**SIZE:** 1.138" +/- .003" (28.9mm +/- .08mm)  
**SURFACE FINISH:** FROSTED  
**WEIGHT:** NOMINAL 3.4 GRAMS  
**STANDARD PACKING:** 2,500 / CARTON  
**OPI PART NUMBER:** F1138022012

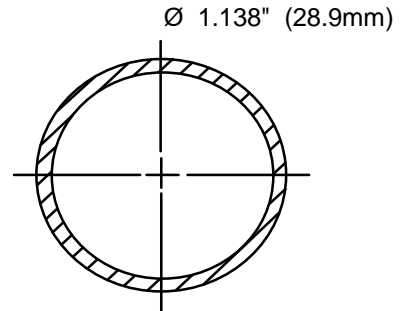

DRAWING NOT TO SCALE

## REVISIONS

REV. #	CHANGE	EFFECTIVE DATE	CHANGED BY	APPROVED BY
A	Nominal wt was 3.7 g.	2010-04-05	TJZ	SPS